

MAC

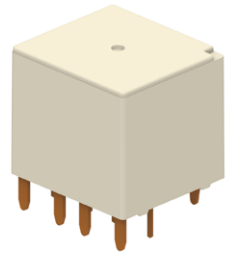

- 25A 电机负载
- 超小型
- 转换型触点形式
- 单, 双继电器可选
- H 级 (180℃) 线圈绝缘等级
- 25A motor locked load
- Extremely small relay
- Change-over contact version
- Single and Dual-bank relays optional
- Coil wire insulation class H (180℃)

	MAC	-	S	-	2	-	12	-	C	-	P
产品型号 Model	产品结构 Structure	触点组数 Contact Group	线圈电压 Coil Voltage	触点形式 Contact Form	线圈功耗 Coil Power						
	S: 塑封型 S: Sealed	1: 单继电器 2: 双继电器 1: Single Relay 2: Dual-bank Relay	12: 12VDC	C: 转换 C: NO/NC	P: 低动作电压型 无: 标准型 P: Low pick-up voltage Nil: Standard						

触点参数 Contact Parameters

触点形式 Contact Arrangement	1C: 单继电器 Single Relay 2C: 双继电器 Dual-bank Relay
触点材料 Contact Material	银合金 Silver Alloy
接触压降 Voltage Drop(初始 Initial)	典型值 Typ.50mV, 最大值 Max.250mV
最大切换电流 Max.Switching Current	30A
最大切换电压 Max.Switching Voltage	16VDC
电气寿命 Electrical Life	见附表 1 See schedule 1
机械寿命 Mechanical Life	1×10^6 次 OPS

性能参数 Characteristics

绝缘电阻 Insulation Resistance	100MΩ(500VDC)
介质耐压 Dielectric Strength	触点与线圈间 Between Coil, Contacts: 500VAC 1min 断开触点间 Between Open Contacts: 500VAC 1min
动作时间 Operate Time	≤10ms
释放时间 Release Time	≤10ms
环境温度 Ambient Temperature	-40℃ ~+125℃
振动 Vibration	10Hz~500Hz 49m/s ²
冲击 Shock	98m/s ²
引出端方式 Terminal Form	印刷电路板引出端 PCB
封装形式 Construction	塑封型 Sealed
重量 Unit Weight	1C: 约 Approx 4g 2C: 约 Approx 8g

线圈规格表 Coil Data(23℃)

类型 Type	额定电压 Rated Voltage VDC	动作电压 Operate Voltage VDC	释放电压 Release Voltage VDC	线圈电阻 Coil Resistance $\Omega \pm 10\%$	线圈功率 Coil Power W	允许最大线圈电压 (1) Max.Allowable Overdrive Voltage VDC	
						20℃	85℃
标准型 Standard	12	≤7.2	≥1	225	约 Approx. 0.64	20	16
低动作电压型 Low pick-up voltage	12	≤6.5	≥1	180	约 Approx. 0.8	18	14

注意：(1) 触点无负载电流，线圈电阻为最小值情况下，继电器线圈允许施加的最大连续工作电压。

Be careful:(1)Max.Allowable overdrive voltage is stated with no load applied minimum coil resistance.

附表 1 Schedule 1

负载电压 Load Voltage	负载类型 Load Type		负载电流 A Load Current		通断比 s On/Off Ratio		电耐久性 (次 OPS) Electrical Endurance
			1C, 2C		接通 On	断开 Off	
			常开 NO	常闭 NC			
14VDC	电机负载 Motor	接通 Make	25	--	0.5	9.5	1×10^5
		断开 Break	25	--			
	模拟车窗升降 Simulate Window Operation	接通 Make	25	--	0.2	4	1×10^5
		稳态 Stable	10	--	2.3		
		断开 Break	25	--	0.5		
	模拟马达自由运转 Simulate Motor Operation	接通 Make	27	-	0.02	1.8	1×10^5
		稳态 Stable	17	-	0.03		
		断开 Break	8	-	0.15		

外形尺寸 Outline Dimensions

单位 Unit: mm

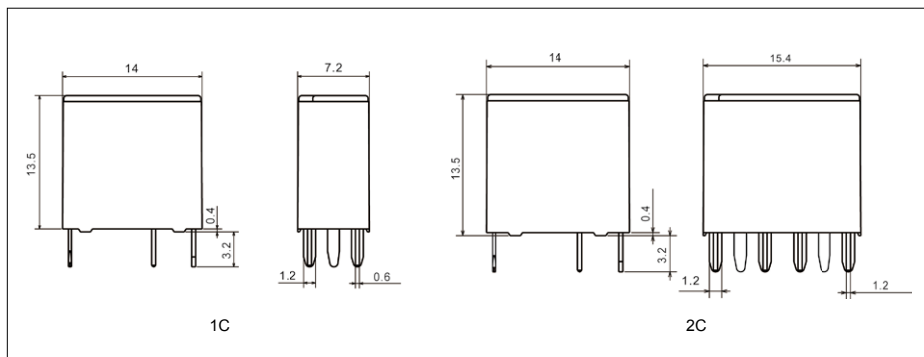

安装孔尺寸 (底视图) PCB Layout (Bottom View)

单位 Unit: mm

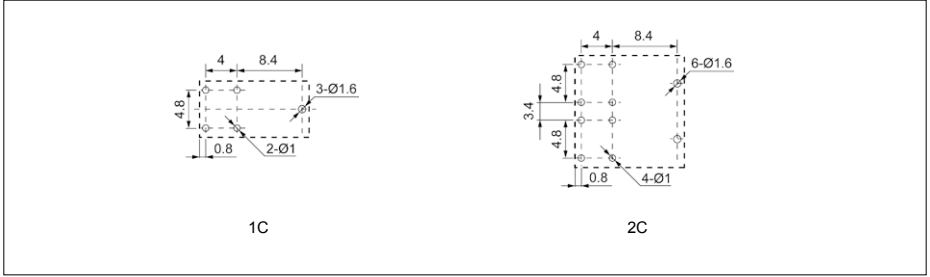

接线图 (底视图) Wiring Diagram (Bottom View)



- 备注: (1) 产品部分外形尺寸未注尺寸公差, 当外形尺寸 $\leq 1\text{mm}$, 公差为 $\pm 0.2\text{mm}$; 当外形尺寸在 $1\sim 5\text{mm}$ 之间时, 公差为 $\pm 0.3\text{mm}$; 当外形尺寸 $> 5\text{mm}$ 时, 公差为 $\pm 0.4\text{mm}$; (2) 安装孔尺寸中未注尺寸公差均为 $\pm 0.1\text{mm}$ 。

REMARK:

- (1) In case of no tolerance shown in outline dimension: outline dimension $\leq 1\text{mm}$, tolerance should be $\pm 0.2\text{mm}$; outline dimension $> 1\text{mm}$ and $\leq 5\text{mm}$, tolerance should be $\pm 0.3\text{mm}$; outline dimension $> 5\text{mm}$, tolerance should be $\pm 0.4\text{mm}$;
 (2) The tolerance without indicating for PCB layout is always $\pm 0.1\text{mm}$.

性能曲线图 Performance Curve

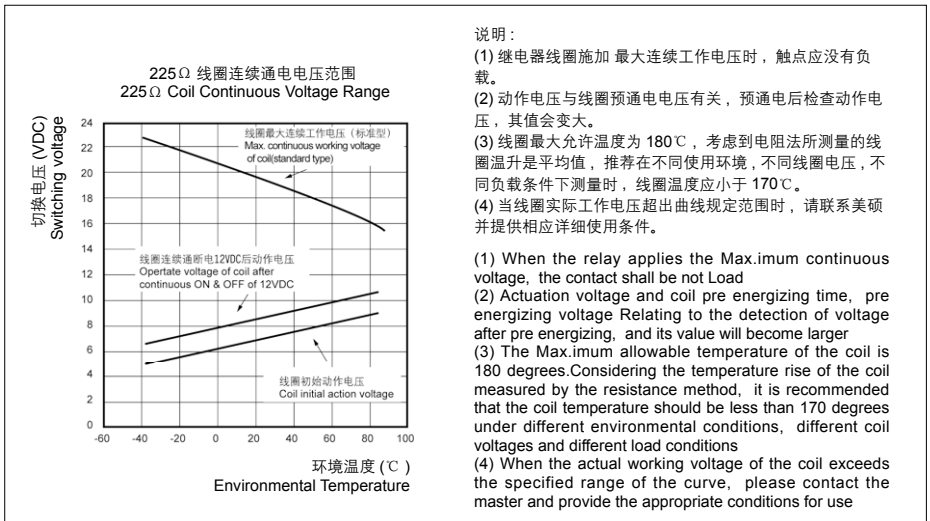

性能曲线图 Performance Curve

180Ω 线圈连续通电电压范围
180Ω Coil Continuous Voltage Range

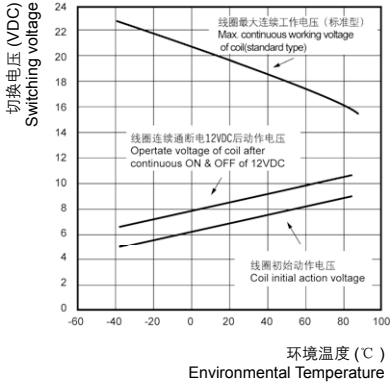

说明:

- (1) 继电器线圈施加最大连续工作电压时, 触点应没有负载。
- (2) 动作电压与线圈预通电电压有关, 预通电后检查动作电压, 其值会变大。
- (3) 线圈最大允许温度为 180℃, 考虑到电阻法所测量的线圈温升是平均值, 推荐在不同使用环境, 不同线圈电压, 不同负载条件下测量时, 线圈温度应小于 170℃。
- (4) 当线圈实际工作电压超出曲线规定范围时, 请联系美硕并提供相应详细使用条件。

- (1) When the relay applies the Max.imum continuous voltage, the contact shall be not load
- (2) Actuation voltage and coil pre energizing time, pre energizing voltage Relating to the detection of voltage after pre energizing, and its value will become larger
- (3) The Max.imum allowable temperature of the coil is 180 degrees.Considering the temperature rise of the coil measured by the resistance method, it is recommended that the coil temperature should be less than 170 degrees under different environmental conditions, different coil voltages and different load conditions
- (4) When the actual working voltage of the coil exceeds the specified range of the curve, please contact the master and provide the appropriate conditions for use

允许最大负载范围 (23℃)
Max.imum allowable load range

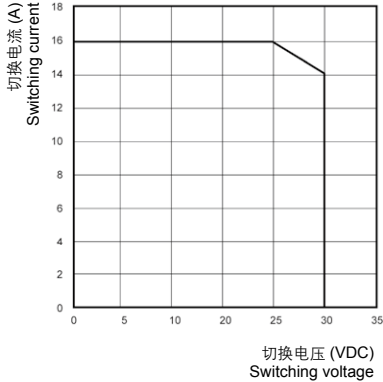

说明:

- (1) 本图以常开触点为例, 本图电流为阻性。
- (2) 产品按触点参数表进行负载与耐久性试验, 当实际使用的负载电压, 电流, 动作频率任一项与触点参数表不同时, 请重新进行确认试验。

- (1) Take the normally open contact as an example, the current is resistive
- (2) Load and durability test shall be carried out according to the contact parameter list.When the actual load voltage, current and action frequency are not the same as the contact parameters, please confirm the test again.